



An Ovivo Company

GAS CONTROL

VAREC BIOGAS 5200 Series FLAME CHECK

The 5200 Series Flame Check is designed to stop flash-backs in small pipe lines carrying flammable gases.

Applications

The 5200 Series Flame Checks are installed in small pilot lines to fuel burning devices and in vent piping from manometers and diaphragm operated regulators. The flame check should always be installed as near as possible to the open end of the vent pipe or source of flame.

Operation

Flame checks prevent the propagation of a flame through the principle of dissipation. If a flashback is generated, it is extinguished before it passes through the internal element. The compressed woven wire element absorbs heat from the flame front faster than it is developed. The temperature of the flame is lowered below its ignition point, thus quenching the flame.

The large net free area in the flame arresting element provides increased flow capacity with minimal pressure drop. In addition, the element design maximizes surface area for greater dissipation of heat resulting in maximum fire protection. The flame check housing is designed similar to a pipe union permitting easy disassembly to remove the flame arresting element for inspection and cleaning.



Design Features

The 5200 Series Flame Check is available in 1/4" through 2" sizes with NPT connections. The housing is constructed of low copper cast aluminum which is non-corrosive in hydrocarbon gases and resistant to H₂S and other corrosive elements. The flame arresting element is 316 Stainless Steel. Maximum working pressure is 25 PSIG (172 kPa) as standard.

Technical

- Large Net Free Area for Maximum Flow
- 25 PSIG Working Pressure
- Pipe Union Type Housing Permits Easy Disassembly
- Compressed Woven Wire Element Design Maximizes Fire Protection

Sizes

1/4", 1/2", 3/4", 1", 1 1/2", 2 NPT

Housing Material

Low Copper Cast Aluminum

Element Material and Thickness

316 Stainless Steel

Working Pressure

25 PSIG (172 kPa) Maximum

Specifications

Dimensions and Weights, inches [mm] and lbs. (kg)

Size Code	1	2	3	4	5	6
A	1/4 [6]	1/2 [13]	3/4 [19]	1 [25]	1 1/2 [38]	2 [50]
B	2 [51]	2 3/4 [70]	2 3/4 [70]	3 1/2 [89]	3 1/2 [89]	4 3/4 [121]
C	2 3/4 [70]	3 1/2 [89]	3 1/2 [89]	3 1/2 [89]	3 1/2 [89]	4 1/2 [114]
Shipping Weight	1 (0.5)	2 (0.9)	2 (0.9)	3 (1.4)	3 (1.4)	4 (1.8)

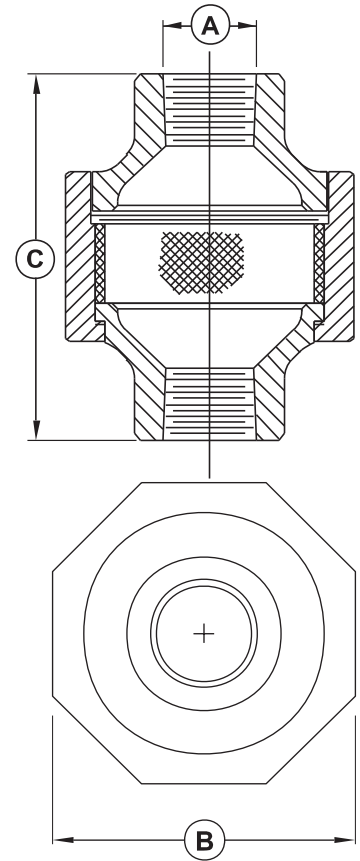

Flow Curves 5200 SERIES

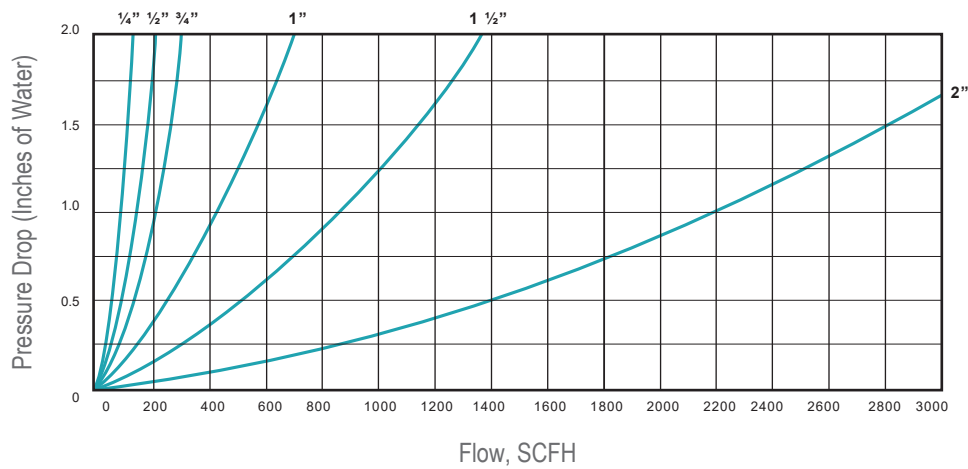

Ordering Information

Model	Description	
5200	Low Pressure Flame Check	
	Code	Size
	1	1/4"
	2	1/2"
	3	3/4"
	4	1"
	5	1 1/2"
	6	2"
	Code	Element Material
	2	316 Stainless Steel (Standard)

5200 2 2 (Example)

Example: 5200 Flame Check, 1/2" Size, 316 SS Element.