



An Ovivo Company

VAREC 5000 / 5010 Series FLAME ARRESTERS

The 5000 / 5010 Series end-of-line flame arresters are used in gas piping systems, petroleum storage tank roofs and digester covers to prevent the propagation of a flame into the system.

Introduction

The arresters are designed to stop the propagation of flame (Group "D" gases) from external sources. They can be mounted up to 15 feet upstream of the ignition source in accordance with UL approval, or 10 pipe diameters in accordance with FM approval requirements.

5000 Series is for vertical installation. 5010 Series is for horizontal or vertical installation.

Operation

Varec 5000 and 5010 Series Flame Arresters stop the propagation of a flame by absorbing and dissipating heat through the surface area of the bank sheets. Ignited vapor attempting to pass through the arrester is forced through small passages within the bank assembly. Heat is absorbed, lowering the temperature of the gas below its ignition point and quenching the flame.

Design Features

The net free area through all 5000 and 5010 Series Flame Arrester banks is three to four times the unit pipe size, resulting in increased flow capacity with minimal pressure drop. The large surface area of the bank also improves heat dissipation.

Varec 5000 and 5010 Series Flame Arresters are designed with a unique extensible aluminum bank frame (see photos on page 2). The corrugated sheets can be individually inspected and routinely cleaned without removal from the frame.

If the bank assembly requires replacement, the frame slides easily out of the arrester. It is not necessary to jack apart the end housings or connecting piping.

Additionally, the unitized housing does not require support for proper bank alignment during maintenance, as may be necessary with spiral bank arresters. This is especially useful in applications where frequent inspection and cleaning is anticipated.

The 5010 Series is designed with an "off-set" housing, providing an advantage over symmetrical housings and spiral bank designs. Generally, flow capacity is not affected by condensate accumulation, even when installed in horizontal piping. By design, the bank is positioned above any area where condensate would accumulate. Each unit is fitted with a 1/2" NPT drain plug at the low point, conveniently located for routine draining.



A Varec Drip Trap should be specified for field installation at this connection to provide for safe removal of condensate.

Technical Data

- Removable cover plate and extensible bank assembly for easy inspection and cleaning
- Three to four times net free area through bank
- UL Approved
- Heavy wall cast housing in 356 T6
- Aluminum, Carbon Steel or 316 Stainless Steel
- Vertical or Horizontal Configuration

Specifications

Sizes

2", 3", 4", 6", 8", 10" and 12"

Connections

Aluminum drilled to ANSI Class 150 Dimension Flat-Faced Flange

Carbon Steel and 316 Stainless Steel Drilled to ANSI Class 150 Dimensions, Raised-Face Flange Connection

Special drilling of flange connections to DIN, JPI or JIS standards available upon request. Consult factory or your local sales representative for further details.

Pressure Rating

Leak proof to 10 PSI [69.0 kPa], Standard Higher Ratings Available, Consult Factory

Pressure Drop

Should Not Exceed 1 PSI [6.9 kPa]

Location

Within 15 feet (4.6m) upstream of flame source

Configuration

NET FREE AREA

Three to four times the corresponding size standard pipe.

BANK ASSEMBLY

Extensible Aluminum Bank Frame with corrugated rectangular shaped bank sheets

Fixed 316 Stainless Steel Bank Frame

PROVISION FOR DRAINING

5000 Series Self Draining

5010 Series includes 1/2" NPT Connection at low point

Housing Materials

356 - T6 Low Copper Aluminum - Standard

Carbon Steel (ASTM A216 Grade WCB) - Optional

316 Stainless Steel - Optional

Bank Assembly Material

Low Copper Aluminum extensible frame with Aluminum Bank Sheets - Standard

Low Copper Aluminum extensible frame with 316 Stainless Steel bank sheets - Optional

All 316 Stainless Steel fixed frame with 316 Stainless Steel bank sheets – Optional (available with Carbon Steel or 316 Stainless Steel housing only)

Approvals

5000 Series UL (Underwriters Laboratories) listed in all Aluminum construction with extensible bank assembly in 2", 3", 4", 6", and 10" sizes.¹

5010 Series UL listed in all Aluminum construction as above in 2", 3", and 4" sizes.¹

NOTE: 1 - For use on hydrocarbon storage tanks, installed NOT MORE THAN 15 FEET from the open end of the vent pipe. These test conditions may not represent the actual service conditions of piping system design. It is recommended that the arrester be independently tested under actual service conditions before installation.

Extensible Aluminum Bank Frame - 5000 and 5010 Series

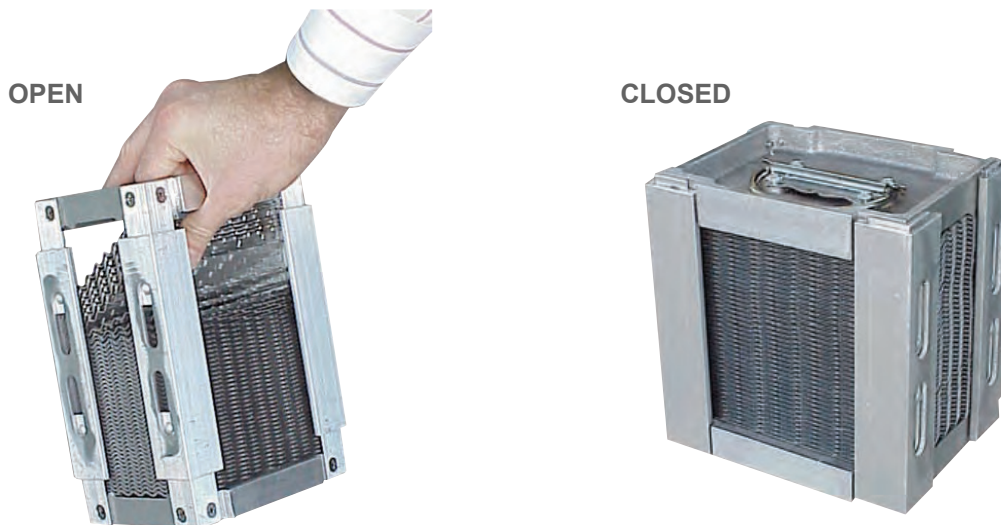

Specifications

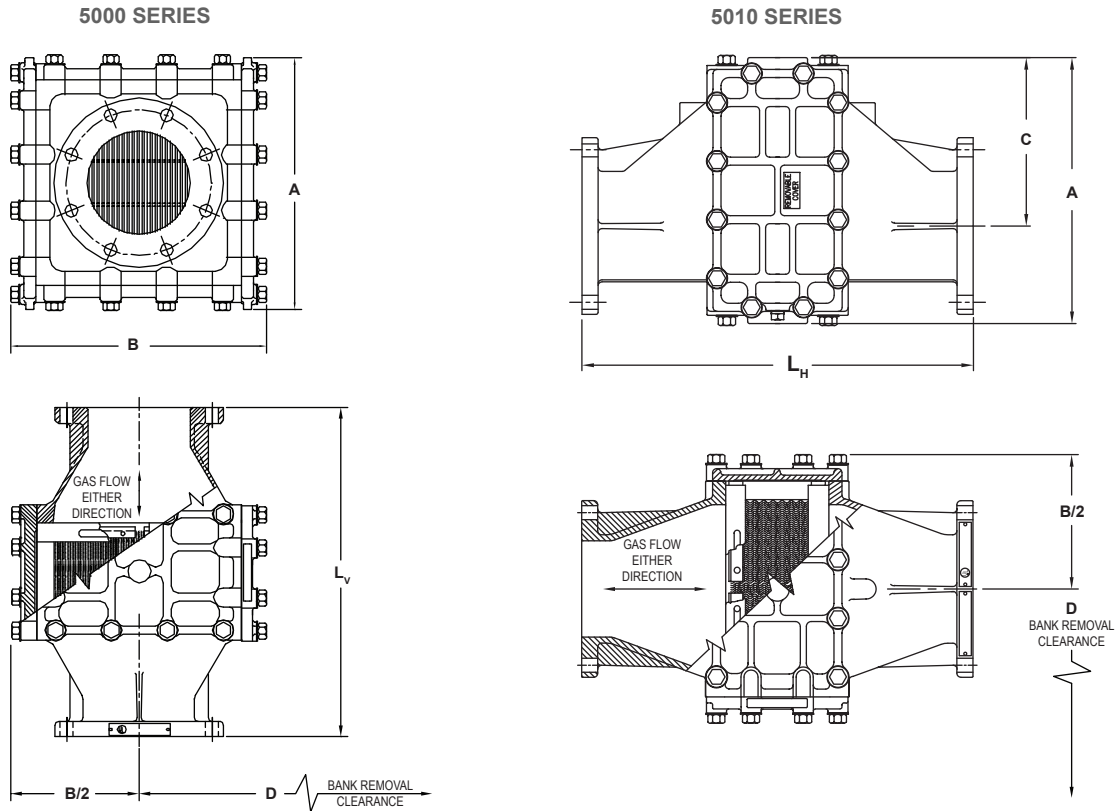

Dimensions and Weights, inches [mm] and lbs. (kg)

Size Code	2	3	4	6	8	10	12
Nominal Pipe Size	2	3	4	6	8	10	12
L_V Length (5000)	12 ⁵ / ₈ [321]	13 ⁷ / ₈ [352]	16 ⁵ / ₈ [422]	21 ¹ / ₂ [546]	27 ¹ / ₄ [692]	28 ³ / ₈ [721]	34 ³ / ₈ [873]
L_H Length (5010)	14 ¹ / ₂ [368]	16 [406]	20 [508]	24 ³ / ₈ [619]	32 ¹ / ₈ [816]	35 ¹ / ₂ [902]	34 ³ / ₈ [873]
A Width	9 [229]	11 ³ / ₄ [298]	14 ¹ / ₂ [368]	16 ¹ / ₂ [419]	21 ⁵ / ₈ [549]	24 [610]	31 [787]
B Depth	8 ⁵ / ₈ [219]	11 ¹ / ₂ [292]	14 ³ / ₄ [375]	16 ¹ / ₂ [425]	21 ³ / ₄ [552]	23 ³ / ₄ [603]	29 ¹ / ₄ [743]
C CL Offset (5010)	5 ³ / ₈ [137]	7 ¹ / ₄ [184]	9 [229]	10 ³ / ₄ [273]	14 ³ / ₈ [365]	16 [406]	20 [508]
D Bank Clearance	19 [483]	23 ¹ / ₄ [591]	28 ¹ / ₈ [714]	31 ¹ / ₈ [791]	38 ⁵ / ₈ [981]	41 ⁵ / ₈ [1057]	50 [1270]
Aluminum	25	45	65	100	200	240	350
Shipping Wt. (5000)	(11)	(20)	(30)	(45)	(91)	(109)	(159)
Aluminum	30	50	70	115	220	270	375
Shipping Wt. (5010)	(14)	(23)	(32)	(52)	(100)	(123)	(170)

Note: Flange drilling per ANSI Class 125 flat face flange (Aluminum) per ANSI Class 150 raised face flange (Carbon Steel and 316 Stainless Steel)

Ordering Information

Model	Description		
50	Flame Arrester		
	Code	Configuration	
	00	Vertical	
	10	Horizontal	
		Code	Size
		2	2"
		3	3"
		4	4"
		6	6"
		8	8"
		0	10"
		1	12"
		Code	Housing/ Bank Assembly Frame/ Sheet Material
		1	Aluminum/ Aluminum (Extensible Frame)/ Aluminum
		2	Aluminum/ Aluminum (Extensible Frame)/ 316 Stainless Steel
		3	Carbon Steel/ 316 Stainless Steel (Fixed Frame)/ 316 Stainless Steel
		6	316 Stainless Steel/ 316 Stainless Steel (Fixed Frame)/ 316 Stainless Steel
		Code	Hardware Material
		*	Leave Blank When Ordering Standard Zinc Plated Steel
		S	Stainless Steel (Optional)