



An Ovivo Company

BURNERS/ FLARES

VAREC BIOGAS 244W Series WASTE GAS BURNER & IGNITION SYSTEM

The Varec Biogas 244W Series Waste Gas Burner is a highly reliable flare and ignition system ideal for use in burning excess biogas.

Introduction

The Varec Biogas 244W Series Waste Gas Burner is a highly reliable flare and ignition system. The pilot has proven reliability even in extreme climate conditions. The 244W Series is ideal for use in burning excess biogas.

Application

Excess biogas must be disposed of safely. The gas is flared to avoid an odor nuisance or an explosion hazard. Biogas is generated through the anaerobic digestion of organic solids. It is produced in municipal or industrial anaerobic digesters, lagoons, and municipal landfills. Biogas is typically a highly-moist mixture of gases. It consists of approximately 55 to 70% methane, 25 to 35% carbon dioxide and trace amounts of nitrogen, hydrogen sulfide, and water vapor. The biogas often has a fluctuating flow and BTU value. The 244W Series is designed to operate reliably at low and high flow rates, and is not affected by changes in the biogas BTU value.

Operation

The Varec Biogas 244WS Series Burner is a state-of-the-art, candle-stick flare. The burner utilizes a patented pilot ignition system. Pilot gas and air are mixed and ignited at ground level, remote from the burner stack. This controlled method results in a stable pilot flame with an ideal gas-to-air ratio. The pilot burns a true stoichiometric, non-smoking flame. It is not affected by changes in the biogas flow rate or BTU content.



The electronics package controls automatic pilot ignition and monitoring. During the ignition cycle, pilot gas is directed to the flame retention nozzle. Pilot gas is also directed to the venturi where air is inspired. The air/ gas mixture is ignited at the venturi outlet. The ignition generates a flame front which travels through the continuous flame line and exits the continuous flame nozzle at the burner tip. Gas flowing in the flame retention nozzle is ignited by this flame front.

A thermocouple is installed in the continuous flame nozzle. When it reaches its temperature setting, the pilot gas flowing in the secondary flame retention line is shut-off. Pilot is flowing only on the continuous flame line and only when there is demand to combust biogas at the burner. In case the pilot is lost, automatic pilot reignition occurs in AUTO mode. If the burner goes through the number of reignition attempts within the set time and the thermocouple fails to reach its temperature setting, a system alarm comes on requiring a manual re-set.

Design Features

The 244W Series design includes features that provide reliable and efficient operation. The flare can withstand wind loading of 150 mph (242 km/h) and wind speeds of 110 mph (180 km/h). Baffles, downdraft preventers, vortex vanes, and secondary stacks are not required. The inclined continuous pilot nozzle provides a long-profile flame which penetrates the waste gas as it passes through. This feature ensures the biogas is ignited at near zero flows.

Installation has been simplified. The burner allows for high turndown ratios; removing the need to manifold several burners together. Pre-cast concrete supports are not necessary either. The burner includes an integral ANSI 150 RF flange. The contractor just has to provide a matching flange and pipe supports. These features keep installation costs to a minimum.

The venturi-driven pilot burns at higher temperature when fueled by propane, natural gas or biogas (see 244WG or 244WL systems). This improves H₂S conversion, which reduces odor to a minimum. The heavy-wall continuous pilot nozzle and flame retention nozzle are both mounted at the burner tip. The nozzles are designed to withstand the elevated pilot temperature and H₂S environment. A heavily protected thermocouple permits pilot flame monitoring. The thermocouple provides an extremely reliable pilot signal.

Contacts are provided as standard for remote pilot indication and system alarm. HAND and AUTO ignition mode is selectable.

The 244WS is designed to operate satisfactorily in very cold climates.

The large venturi design allows the ignition components to be mounted up to 100 feet (30 m) away from the burner. The control package may also be mounted at this distance without suffering any performance loss.

The venturi includes a backflash preventer for safety. An anti-clog orifice is supplied which eliminates the need for pilot filters. The Model 244WS is designed with operator safety in mind. All hi-tension leads and sparking devices are located a safe distance from the flame. Typical adjustments and maintenance are performed at ground level, away from the heat of combustion. Ignition components are also located remote from the burner, which provides optimum serviceability.

244WG Series Low Pressure Pilot Ignition System

The 244WG option is specifically designed to burn biogas efficiently with the use of low pressure biogas for pilot fuel (10" < pilot gas pressure < 14" WC) without the requirement of blower-assisted fuel or air.

The burner comes with two inspirating venturis to help pre-mix air and pilot gas and ensure pilot reliability and efficient combustion of biogas even with the low volume biogas pilot fuel. The control panel and pilot gas control components are mounted on stainless steel plate. It is installed a maximum of 10 feet horizontal distance from the waste gas burner. The pilot gas piping from the venturis to the waste gas burner connection must be a straight pipe – no pipe bends allowed. This will ensure that the stoichiometric gas can travel to the burner tip.

The 244WG also utilizes flamefront technology like the 244WS option and follows the same operation scheme.

244WL Series Low Pressure Pilot Ignition System

The 244WL ignition system utilizes the same industry standard flame front technology used in our Model 244W Waste Gas Burners. The pilot gas control panel can be mounted up to 70 ft. (seventy feet) from the burner stack. It can utilize biogas, natural gas or propane at pressures as low as 10" WC.

The 244WL ignition system no longer requires a straight pilot gas piping run from the pilot gas control panel to the burner stack. Using 45 degree elbows, provides greater flexibility during design and installation.

The "L" ignition system comes equipped with a blower to pre-mix air with the pilot gas to achieve the proper air/ gas mixture required for combustion. This pre-mixing of pilot gas and air insures that the pilot stays lit under virtually all flow and weather conditions.

The sparkplug is located at the exit of the 2" mixing chamber. A flame front travels on the 2" pilot gas line and as it exits the burner stack, the 1/2" retention line is there to capture the flame front. The angled design of the pilot gas piping has been field tested to achieve the proper air/ gas mixture needed for optimum combustion of the waste gas.

All serviceable items are located remotely from the burner stack which protects all electrical components from the heat of combustion. More importantly, Operators are protected from radiant heat effects from the waste gas burner when it is in operation.

BLOWER PACKAGE

A blower package is available when the pilot gas supply is less than 10 psig (70 kPa) and as low as 8" W.C. (2 kPa) pressure.

The burner stack and control panel design is the same as the standard 244WS with a venturi.

This option can also handle the same burner flow capacities. Local or "Remote-Start" features are still available. You retain the advantage of having the theory of operation using flame front technology.

A blower panel replaces the venturi and valve & regulator panel and utilizes a blower to pre-mix air and pilot gas. The blower comes with an air/ gas mixing chamber to achieve proper air/ gas mixture and is ignited at the chamber exit. It also includes the pilot gas solenoid valves, regulators and gauges required to control pilot gas.

See the Sample Specification Product Data Sheet for more information.

Optional Features

“REMOTE-START”

If biogas will be flared intermittently, an option to conserve pilot fuel is available through our “Remote-Start” pilot ignition option. It includes a pilot-gas supply solenoid valve, which opens when pilot ignition is required and remains open while the gas is flaring. The solenoid may be specified to: (a) fail open which will continue to deliver pilot fuel during a power failure and keep the burner operational in an emergency condition, or (b) fail close, which is used when a blower is available to deliver the biogas to the burner (“L” ignition system).

The “call for ignition” signal may be provided by a pressure switch, flow-switch, or through a contact change-over.

FLASHBACK PROTECTION

It is recommended that suitable flame flashback protection be installed in fuel gas lines supplying any of the 244W burner systems. Please refer to 5200 Series Product Data Sheet for information.

CONTROL

The standard control panel is provided with a programmable logic controller (PLC). The PLC can be provided with HMI touch screen controls. Relay logic panels available upon request.



HEATER & THERMOSTAT

For ambient temperatures below -20°F (-29°C), a heater and thermostat is recommended.

REMOTE SPARK GENERATOR

The hi-tension lead wire supplied with the unit is a maximum 10 feet (3 m) in length. In cases where the control panel that houses the transformer cannot be located within 10 feet of the spark plug location, a remote generator can be specified.

The transformer is supplied in either a NEMA 4, 4X or 4 & 7 enclosure and located within 10 feet of the spark plug. This allows an operator to have the control panel installed further away from the burner for improved burner monitoring.

Specifications

SIZES

2”, 3”, 4”, 6”, 8”, 10” and 12”

CONNECTIONS

Burner Stack:
ANSI 150 RF Flange

CONTROL PANEL

Power Supply Input:
115/ 120 VAC, 60 Hz, Standard
220/ 240 VAC, 50 Hz, Optional
220/ 240 VAC, 60 Hz, Optional

Load:
Maximum 10 AMPS at 120 VAC or
5 AMPS at 220 VAC (50-/ 60 Hz)

Ambient Temperature Rating:
-20°F to +131°F (-29°C to +55°C),
Standard

REMOTE ALARM CONTACTS

SPDT (NC, NO and Common) Contacts
Contact Rating:
2 AMPS at 115 or 240 VAC (50/ 60 Hz)
Function:
Pilot Out and System Alarm

Materials

BURNER

All 304SS, Standard
All 316SS, Optional

PILOT NOZZLES

316 SS

THERMOCOUPLE

316 SS

CONTROL ENCLOSURE¹

NEMA 4, Steel Construction, Standard
NEMA 4X, 316 SS Construction, Optional
NEMA 7, Aluminum Construction with O ring
or Steel, Optional

NOTE:
1. UL Certified

HIGH PRESSURE PILOT GAS SUPPLY

Natural Gas or Propane
Min. Supply Pressure: 10 PSIG (70 kPa)
Max. Supply Pressure: 50 PSIG (450 kPa)
Recommended Pipe Length from Venturi to
Continuous Flame Nozzle:
Minimum Distance: 15 feet (5m)
Maximum Distance: 100 feet (30m)

LOW PRESSURE PILOT GAS SUPPLY

When available pilot gas pressure is less
than 10 PSIG (70 kPa) and greater than 10”
WC (250mm WC).

BLOWER PACKAGE

Natural Gas or Propane
Min. Supply Pressure: 8” WC (200mmWC)
Explosion Proof Motor and Switch, Standard
Recommended Pipe Length from blower
package to continuous flame nozzle:
Maximum distance: 33 feet (10m)

Specifications

244WG Biogas Pilot Ignition System

Dry Biogas Pilot of 500 BTU/ ft³ Minimum
Biogas or Natural Gas Supply Pressure

Supply Pressure:
10" WC min. to 14" WC max.
(100mm WC - 350mm WC)

Recommended Pipe Length from Venturis to Waste Gas Burner (244WG):

Maximum distance: 10 feet (3m)

Only one 90° bend allowed on pilot gas piping, Maximum.

244WL Biogas Pilot Ignition System

Dry Biogas Pilot of 500 BTU/ ft³ Minimum
Biogas or Natural Gas Supply Pressure

Supply Pressure:
10" WC min. to 20" WC max.
(250mm WC - 500mm WC)

Pilot Gas Piping Connections

1. Pilot Fuel Supply - 1" NPT
2. Valve & Regulator Panel Connections.
 - a. Continuous Line - 2" NPT
 - b. Flame Retention Line - 1/2" NPT

Recommended Pipe Length from Venturi Continuous Flame Nozzle:

Maximum Distance: 70 Feet (21m)

45° Bend Allowed on Pilot Gas Piping

NOTE:

Varec Biogas Inc. does not supply the pilot gas piping between the valve & regulator panel to the combustion stack.

GAS TO BE FLARED

Biogas

Composed primarily of Methane (50 - 55%) and CO₂ (40 - 45%)

OPTIONAL FEATURES

Auto-Start Signal (Specify With)

Dry Contact, Standard

Explosion Proof Pressure Switch

Operating Range: 4" - 30" WC

(100mm - 300mm WC)

Deadband: Approximately 0.5" (13mm) WC

Dimensions and Weights, inches [mm] and lbs. (kg)

Size Code	2	3	4	6	8	10	12
Nominal Pipe Size	2 [50]	3 [80]	4 [100]	6 [150]	8 [200]	10 [250]	12 [300]
A	17 [431]	18 [457]	19 [482]	22 [559]	24 [610]	24 [610]	36 [914]
B	20 [508]	24 [610]	24 [610]	32 [813]	48 [1219]	48 [1219]	60 [1524]
C	180 [4572]	180 [4572]	180 [4572]	180 [4572]	180 [4572]	180 [4572]	188 [4775]
Weight (Burner)	190 (86)	259 (118)	308 (140)	450 (204)	601 (273)	810 (367)	1057 (479)

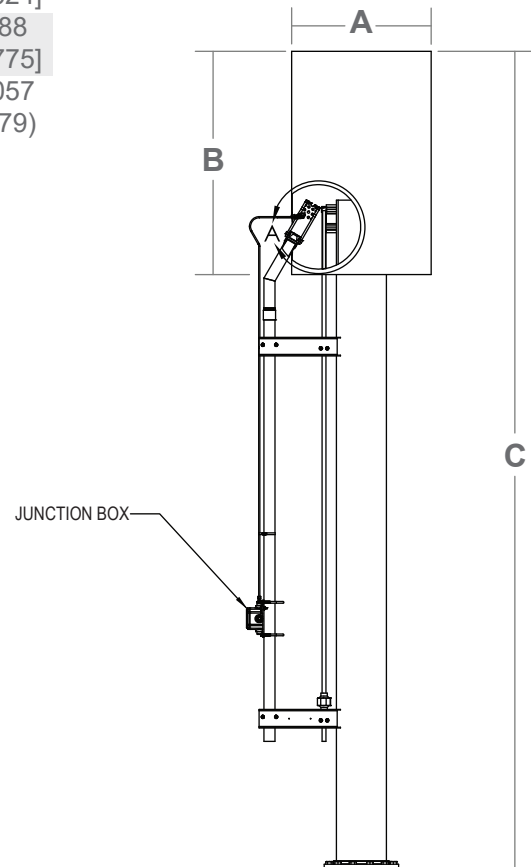
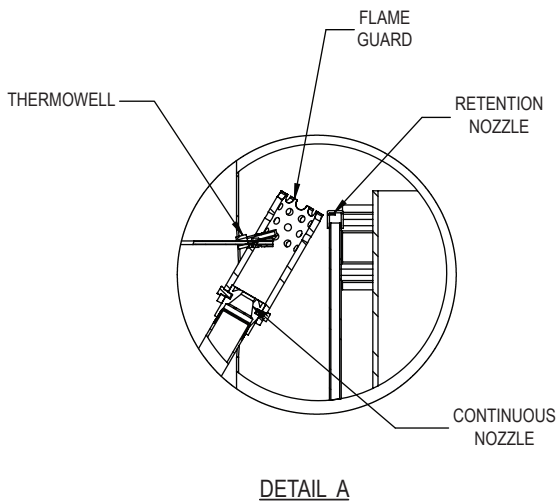

NOTE: Standard height of the flare stack is 15 feet to meet the minimum requirement per ANSI / CSA B149.6. The actual flare tip must be determined based on radiant heat at ground level. Consult factory for assistance. Stack dimensions are the same for all the options available with the 244WS or 244WL.

Specifications

Burning Capacity, FT³ / HR [M³ / HR] - Maximum Flows

Flow stated for biogas with specific gravity of 0.8 at flange connection and 0.5" WC pressure drop at 60°F (15°C) between the inlet flange and burner tip.

Consult factory for flare sizing base on meeting 40 CFR Part 60.18 and Water Environment Federation, Manual of Practice (MOP) No. 8

Size Code	2	3	4	6	8	0	1
	2"	3"	4"	6"	8"	10"	12"
FT³ / HR	3850	11600	22250	51300	88150	150000	250000
M³ / HR	109	328	630	1453	2496	4245	7075
MOP 8 Recommended Maximum Flow Rates*							
FT³ / HR	1100	2500	4275	9520	16350	25580	36170
M³ / HR	31	71	121	270	463	724	1024

*The Water Environment Federation Manual of Practice Number 8 (MOP 8), copyright © 1998 recommends a velocity of no more than 12 feet per second. The maximum flow rates given are based upon Schedule 10 pipe leading up to the burner. Different schedule pipe will have different maximum recommended flow rates.

Figure 01: 244W - Typical Installation

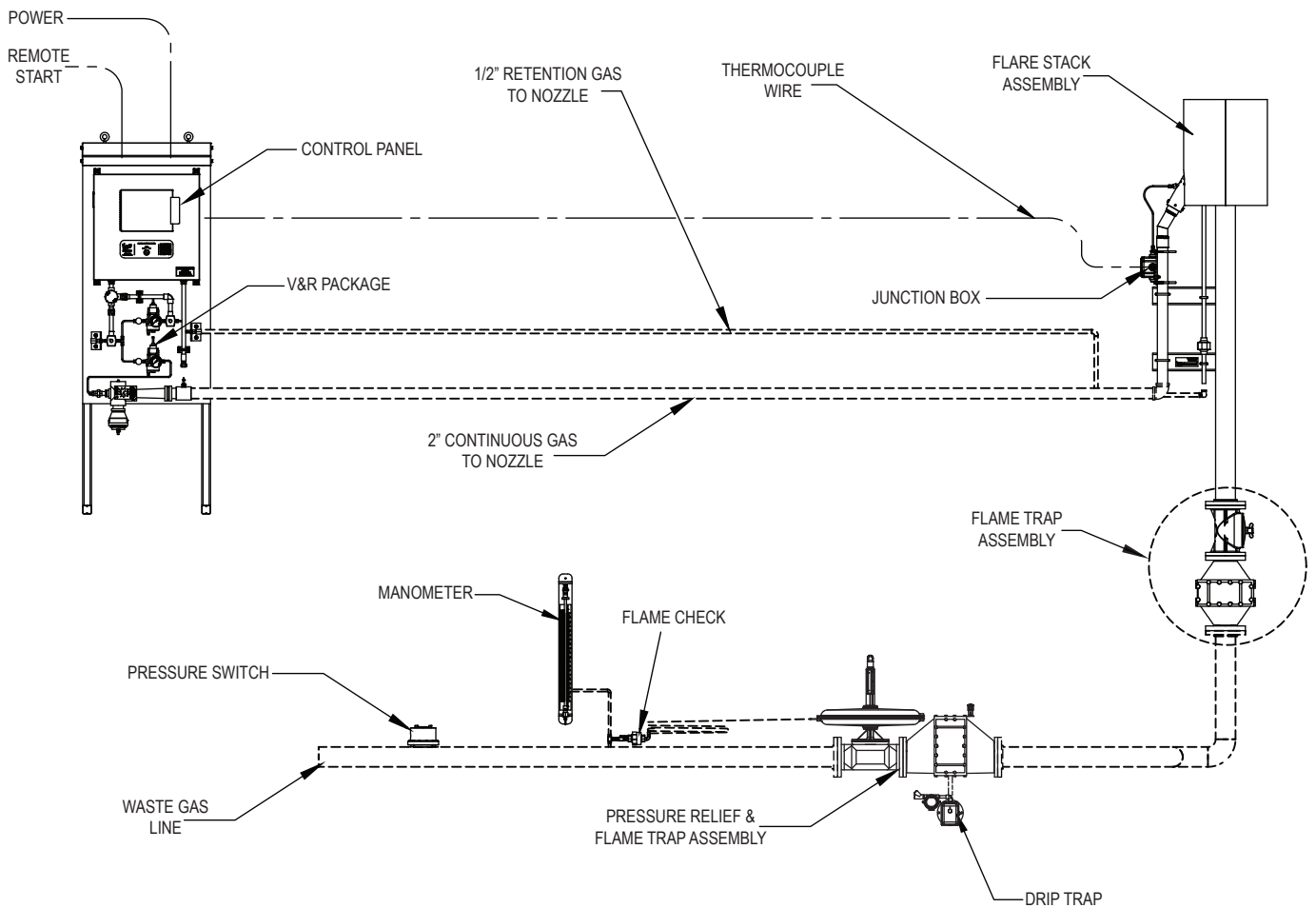

NOTE: Schematic shown is of a typical installation and is not to be used for design or construction purposes.
 A Flame Arrester or Flame Trap Assembly must be installed within 15 feet of the flare flange per UL recommendations.
 The Flame Trap Assembly is not designed to support burner weight. Alternate support may be required and is recommended. Consult factory.

Ordering Information

Model	Description	
244W	Waste Gas Burner & Ignition System	
	Code	Pilot Ignition System
	S	Standard
	G	Low Pressure Pilot Ignition System (Minimum 10" WC Supply Pressure) ¹
	L	Low Pressure Pilot Ignition System (Minimum 10" WC Supply Pressure) ¹
	Code	Size
	2	2"
	3	3"
	4	4"
	6	6"
	8	8"
	0	10"
	1	12"
	Code	Power Requirements (Must Select One)
	1	115/ 120 VAC, 60 Hz (Standard)
	2	220/ 240 VAC, 60 Hz
	3	220/ 240 VAC, 50 Hz
	Code	Electronic Enclosure Rating (Must Select One)
	4	NEMA 4, Weather-Proof (Standard)
	7	NEMA 7, Explosion-Proof (Optional)
	9	NEMA 4X, Stainless Steel (Optional)
	Code	Auto-Start Option (Must Select One)
	0	None - Manual Start
	1	Dry Contact - NEMA 7 Pressure Switch Included
	2	Dry Contact - Pressure Switch Not Required
	3	Auto-Start - NEMA 7 Pressure Transmitter Included
	Code	Pilot Solenoid (Used Only with Auto-Start Option) (Must Select One)
	0	No Auto Start Option Required
	1	Pilot Solenoid Shall Fail Open (Not Avail. w/ Blower)
	2	Pilot Solenoid Shall Fail Closed
	Code	Blower Package Option (Only w/ 244WS)
	Indicate When Specified:	
	0	Standard Venturi-Driven System (Pilot Gas 10PSIG or Greater) or "G" & "L" Pilot Ignition System
	1	Blower-Driven System ²
	Code	Options (May Select More Than One)
	0	None required (Standard)
	1	Heater and Thermostat Mounted within Electronic Enclosure Panel
	2	Remote Spark Generator NEMA 4
	3	Remote Spark Generator NEMA 7
	4	Low Pressure Natural Gas for Pilot Gas (244WG & 244WL)
	5	Propane/ LPG for Pilot Gas (244WS or 244WL Option)
	7	244WG or 244WL Mounting Stand & Weatherhood (316L Weatherhood and Mounting Plate and 304L Stands) ³
	9	Auxiliary Weatherhood and Mounting Stand (316L Weatherhood and Mounting Plate and 304L Stands) ⁴
	R	Relay for use with Model 386/ 440 ⁵
	A	Anchor Bolt Calculations
	B	Standard Support Burner Base for Flare Stack ⁶
	C	CSA Approval (Min. Stack Height, FF Flange, CSA Inspection)
	W	Left Exit Panel (Right Exit - Standard)
	P	Step Down Pilot Gas Pressure Regulator Max 10 PSIG Regulated to 12" WC ⁷
	X	Standard Relay Logic Control Panel
	Y	Special PLC and HMI Requirement - Specify Brand
	Code	Burner Stack, Shroud and Pilot Gas Piping Material ⁸
	*	Leave blank when specifying standard All 304SS
	S6	All 316 SS

244W S 6 1 4 1 1 0 0 (Example)

Example: Standard Unit 6" Flange Connection; Electronic Panel to Accept 120 VAC, 60 Hz Input Power; Housed in NEMA 4 Enclosure. Includes Auto-Start Option with Pressure Switch/ Dry Contact Input and Fail Open Pilot Solenoid Valve

NOTE:

- 1 - 1-5 PSIG supply pressure, include Code P for Pressure Regulator
- 2 - Comes standard with Explosion Proof Motor and Switch.
- 3 - Available option with the 244WG and 244WL.
- 4 - Option can be used for 244WS/ WG/ WL Systems.
- 5 - Include when specifying a 3-Way Solenoid Valve with the Model 386/ 440.

NOTE:

- 6 - Standard design for support base. Add SPC if a special support base is required.
- 7 - Always include with an "L" ignition system.
- 8 - Add S6 at the end of the PN to signify choice of all 316 SS burner stack, shroud and pilot gas piping.